

Manley Installation Guide.

CONTOUR
built-in independence

The Manley Shower Bath is supplied with the following components:-
Bath (LH or RH door opening) with Front Panel
Shower Screen
Twin Waste kit
2 x wall brackets + 2 x Bath Feet - supplied loose

Optional Items:
LH/RH Side Panels (not-handed)

Other Items Required

Thermostatic Valve (TMV22 for high flow rate) - **MUST BE INSTALLED IN ALL CASES.**
Bath Taps/Shower mixer

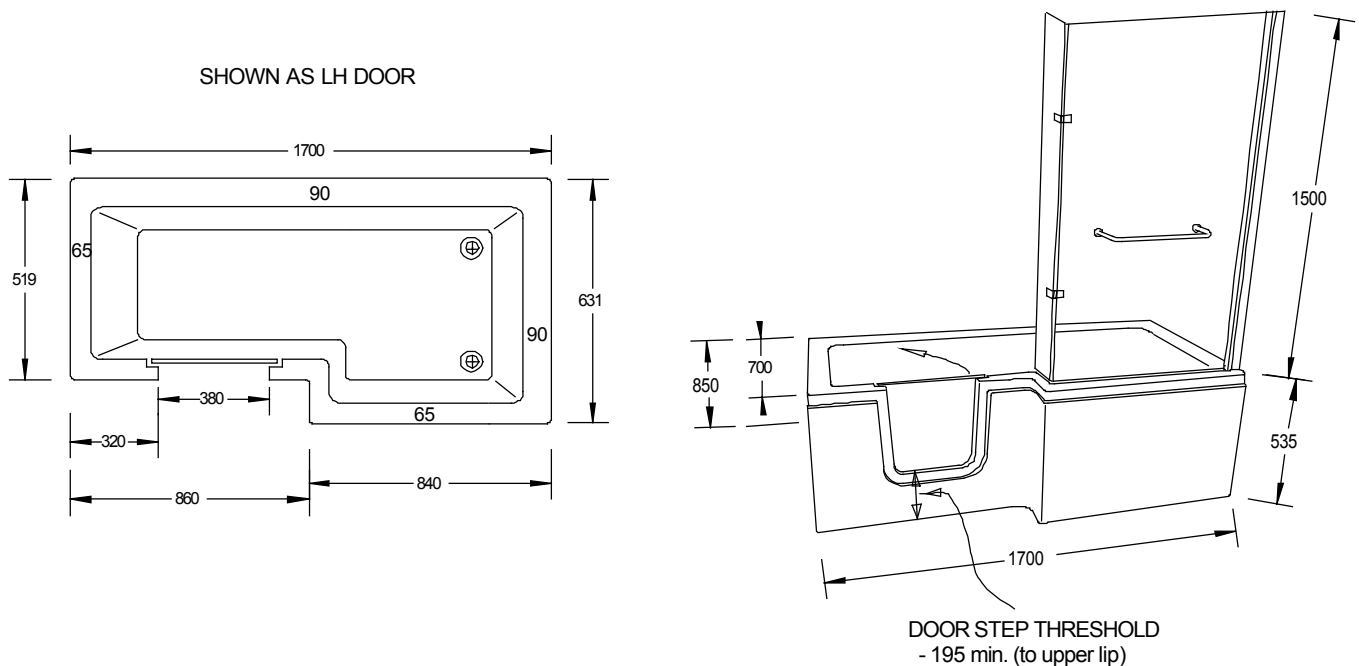

IMPORTANT NOTES

The bath is supplied with 7 adjustable feet. 5 are fitted with 2 outrigger legs supplied loose. It has a water capacity of 215 Litres unoccupied. Bath is filled only when user has entered and shut the door consequently taps must be thermostatically controlled.

Installation is similar as for a standard bath except that twin wastes are supplied to increase drainage rate & to ensure the bath can be drained if one waste fails. The bath should be installed rigidly to ensure there is no movement or sagging of the floor when bath is used.

Consideration should be given to lowering the wastes below the floor level to keep the step threshold to a minimum to assist customer's ability to step into the bath. Use only shallow waste traps.

If fitting in an alcove ensure the bath freely goes into position as sideways pressure can distort the doorway.

The Manley is manufactured in glass fibre. When handling, proceed with care and caution, in particular the bath edges are more brittle than in acrylic baths.

Wet Rooms Direct

Telephone: 01685 898110

Email: sales@wetroomsdirect.net Website: www.wetroomsdirect.net

STANDARD FITTING GUIDE

**** IMPORTANT ****

The Shower Screen must be fitted so as to be displaced by 5mm away from the door into the shower area to contain water splashes.

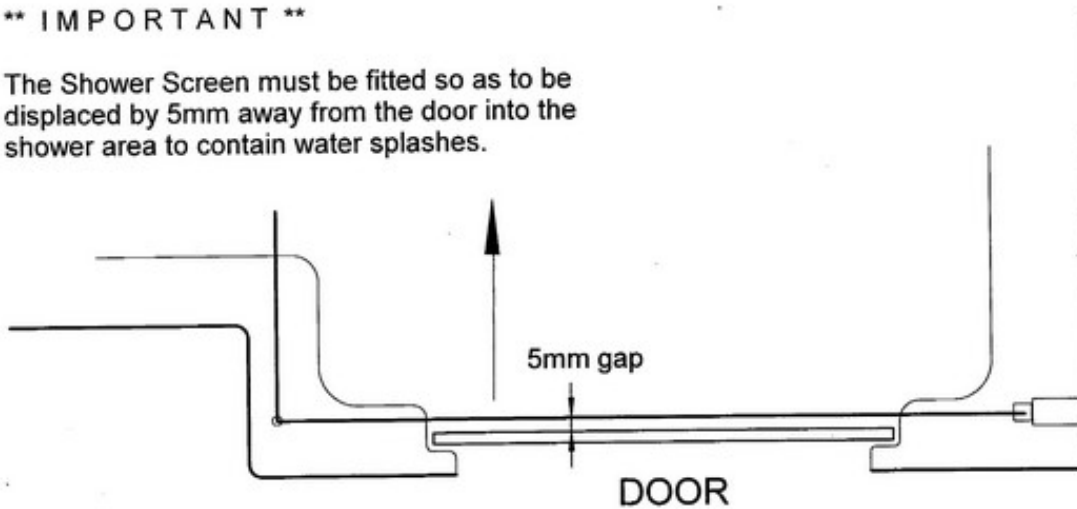

- 1) Manoeuvre bath into bathroom carefully.
 - 2) Secure the 2 Bath feet supplied loose to the plastic sockets underneath the bath.
 - 3) Drill and affix Taps.
 - 4) Fit waste, overflow and waste trap supplied.
 - 5) Place bath in position and adjust to minimum height.
Note: It is advisable to fix batten runs on to the floor under the bath feet to avoid extending the legs to far & to ensure feet sit squarely and flat. On a wooden floor batten runs (3" x 2" minimum) should be positioned squarely across the floor boards to spread the load.
 - 6) Level the bath in all planes using the 7 adjustable feet & then lock the feet. Ensure the bath foot under the doorway is cranked up to support the foot well.
 - 7) Mark wall fixings and plumbing runs.
 - 8) Remove bath, drill in wall fixings where accessible and run plumbing into position.
 - 9) Re-position bath and fix to the floor via all four bath-feet.
 - 10) Connect plumbing. Refer to fitting guides for the Thermostatic valve and Pump if supplied.
 - 11) Test plumbing for leaks and pump operation.
 - 12) Fill bath to maximum and leave for about 20 minutes to test door seal.
 - 13) While the bath seal is being tested position and trim to size the front and side panels.
 - 14) Mark bottom of panels onto floor base. Fix battens along floor behind panels.
 - 15) Refit front and side panels. Drill through bottom into batten and top into bath wooden frame. Push fit panels onto the retaining clips prefitted on the bath sides. Do not use Silicone sealant as this prevents service access.
 - 16) Silicone bath rims to walls as necessary.
 - 17) Install shower screen following the instruction sheet packed with the screen. **** Important – install screen displaced 5mm into shower area as shown above.**
 - 18) Finally drain bath and instruct customer on the use of the bath.
- Refer to the 'User Guide' and leave the copy with customer.
 - Do not leave door in locked position on completion. Advise customer that the door should be left unlocked when not in use in order to preserve the seal.

THE MANLEY BATH

IMPORTANT INSTRUCTIONS FOR CUSTOMER

**PLEASE READ CAREFULLY AND RETAIN FOR FURTHER USE.
IMPROPER USE OR CARE CAN INVALIDATE THE WARRANTY.**

OPERATING INSTRUCTIONS

The MANLEY bath features a watertight glass door held firmly in a locked position by means of a single action cam lock operated by a lever activated steel handle. The door should always be left in an open position when not in use to prevent wear out of the seal.

- 1) When seated in the bath plug up the wastes and push the door to close.
- 2) Push the steel handle away from you fully until it reaches the stop position.

The bath is now watertight and ready for use.

- 3) Turn the taps on and fill the bath to desired depth.
- 4) After bathing release the two wastes and remain seated until all the water is completely drained away.
- 5) Pull on the door handle towards you to unlock the door.
- 6) Exit the bath and leave the door unlocked when not in use to preserve the door seal.

**** NEVER ATTEMPT TO OPEN THE DOOR WHEN BATH IS FULL OF WATER ****

**** DO NOT LEAN UN THE DOOR OR USER FOR SUPPORT ****

**** ALWAYS LEAVE THE DOOR OPEN WHEN NOT IN USE TO PRESERVE THE SEAL****

CARE AND MAINTENANCE

The MANLEY Bath is manufactured to a very high standard in G.R.P. (Reinforced Plastic) to ensure its durability and appearance is maintained over many years of use. It has a robust, smooth and warm surface, which is non-porous, resistant to dirt and bacteria and easy to clean and maintain.

This bath will give many years of service and continue to look good if cleaned correctly and treated with care.

CLEANING

1. As with standard baths, cleaning will vary subject to the scale residue dependant on the hard or soft water level. In soft water areas, wash down with warm water and detergent applied with a soft cloth or sponge. In hard water areas, non-abrasive or mild acid cleansers can be used. Glass Cleaners can be used on door. Clean regularly followed by wiping with a dry soft cloth.

Widely available proprietary plastic/enamel bath cleansers are ideal cleaning agents which offer the advantage of a polished shine without rubbing down.

For the extra sparkle, and to further preserve the surface, the Bath can be gently polished occasionally. Beeswax and Brasso (Brass Polish) are suitable for this purpose. Polishing the anti-slip base should be treated with caution so as not to diminish its effectiveness.

2. The Stainless Steel Locking Handle can be polished occasionally with a stainless steel polish to ensure it does not discolour.
3. The white silicone seal along bath door sides should be cleaned occasionally. Use detergent and warm water applied with a sponge or soft cloth. Apply gently and refrain from excessive rubbing.
4. Ideally all chrome or gold plated furniture should be wiped down dry after use. Clean with soapy water and buff with a dry soft cloth. Note: Surfaces can easily be damaged with acid/abrasive cleaners or with a rough sponge.

CAUTION

- **ALWAYS KEEP THE DOOR OPEN IN AN UNLOCKED POSITION WHEN BATH IS NOT IN USE TO PRSERVE THE DOOR SEAL.**
- **KEEP THE WHITE SILICONE SEAL FREE OF ANY BUILD UP OF DEPOSITS. CLEAN GENTLY AND AVOID UNNECESSARY HANDLING.**
- **DO NOT APPLY ANY UNDUE FORCE TO THE BATH DOOR. HANDLE GENTLY.**

